

Problem Set 7

Please Read the section on Beams on Elastic Foundations in the web notes before doing the next two problems.

1. Beam Resting on a Spring: A beam of constant flexural rigidity EI_z is fixed at end $x=0$ and rests on a linear elastic spring of spring constant K (N/m) at the end $x=L$. If a concentrated transverse load P acts at $x=L$, what is the beam deflection? Use the Rayleigh-Ritz method with an appropriate bag of candidate displacements. [7 points]

2. Beam Resting on an Elastic Foundation: A beam of constant flexural rigidity EI_z is pinned at both ends $x=0$, and $x=L$, and it rests on a *linear elastic foundation* of foundation modulus k (N/m²) for the middle third of its span. If a concentrated transverse load P acts at $x=L/2$, what is the beam deflection? Use the Rayleigh-Ritz method with an appropriate bag of candidate displacements. [7 points]

3. Plate Bending: A thin, square plate of uniform thickness $h = 0.005\text{m}$, and sides $a = 0.5\text{m}$ is simply supported on all four sides. The mid-point of the plate rests on a linear elastic spring of spring constant $K = 2000\text{N/m}$. The entire plate is subject to a uniformly distributed area load $p_o=500\text{N/m}^2$. The plate is made of a linear elastic, isotropic material with Young's modulus $E=100\text{GPa}$ and Poisson's ratio $\nu=0.211$.

(3. i) [5 points] What is the deflection of the plate? Use the Rayleigh-Ritz approach with a suitable one-parameter bag of candidate displacements.

(3.ii) [1 point] What are the maximum bending stresses σ_{xx} , σ_{zz} , σ_{xz} and where do they occur?

4. Column Buckling: What is the critical buckling load of a uniform column both of whose ends are fixed? [5 points]

5. Column Buckling The equilateral triangular truss structure shown in the figure is constructed of two circular tubes, having the following properties: length 3.0m, cross-sectional area $A=10.8 \times 10^{-5}\text{m}^2$; moment of inertia $I_z=7.82 \times 10^{-9}\text{m}^4$. The structure is made of a material whose Young's modulus is $E=0.7 \times 10^{11}\text{Nm}^{-2}$. Also, the material can only withstand a maximum compressive stress of $6.3 \times 10^8\text{Nm}^{-2}$ and a maximum tensile stress of $4.2 \times 10^8\text{Nm}^{-2}$. As the load P is increased slowly, the structure fails. Determine:

(5.i) the tube that fails

(5.ii) the mode of failure, and

(5.iii) the load level at which it fails.

Make reasonable simplifying assumptions. [5 points]

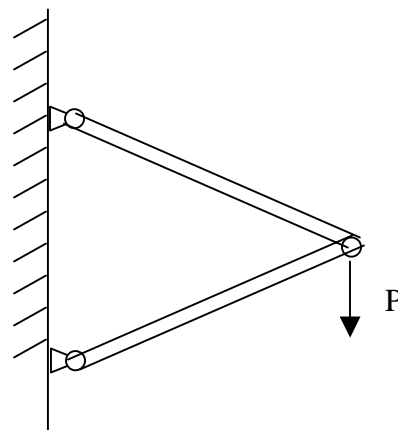

6. Column Buckling Using Rayleigh-Ritz Approach: A cantilever column (fixed at $x=0$ and free at $x=L$) has moment of inertia varying as:

$$I_z = I_1 \left\{ 1 - \frac{x}{3L} \right\}$$

where $I_1 = 4.9 \times 10^{-6} \text{ m}^4$ is the moment of inertia at the fixed end. The material is steel with Young's modulus $E = 2.1 \times 10^{11} \text{ N/m}^2$. If the column is to withstand a maximum compressive load of 10kN, what is the maximum length it can be? Use the Rayleigh-Ritz method using the following bag of candidate displacements $u_y(x) = a_1 (x/L)^2$. [5 points]